

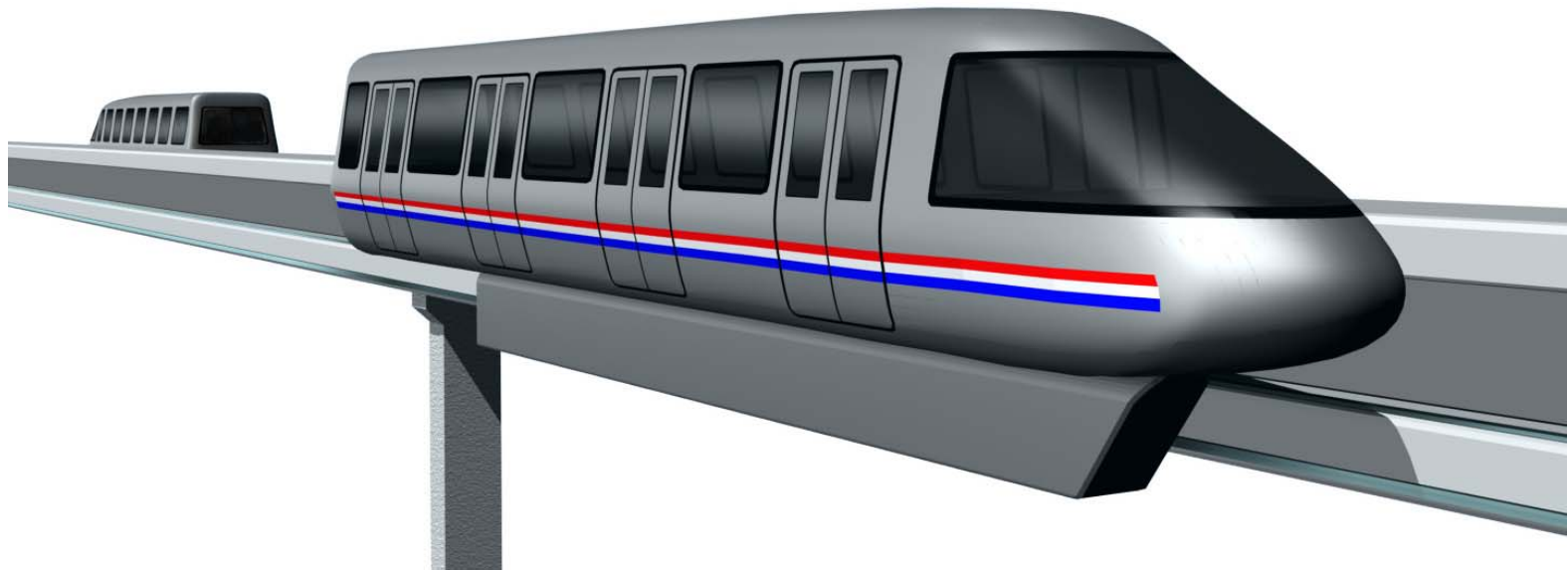

FLORIDA SILVER BULLET

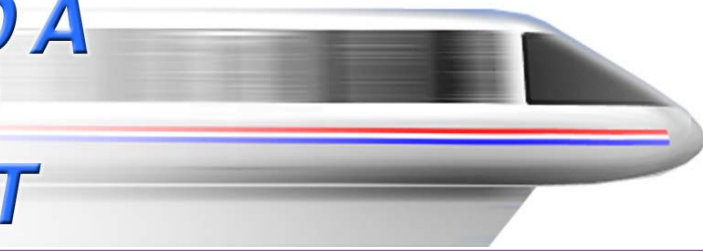

2nd Generation Monorail



GEORGIA
MONORAIL
CONSORTIUM



FLORIDA SILVER BULLET

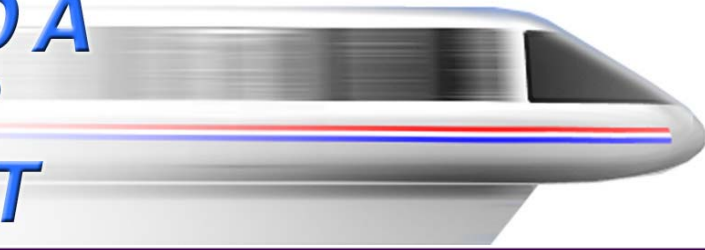

The simple beam shape is the key to the technology.

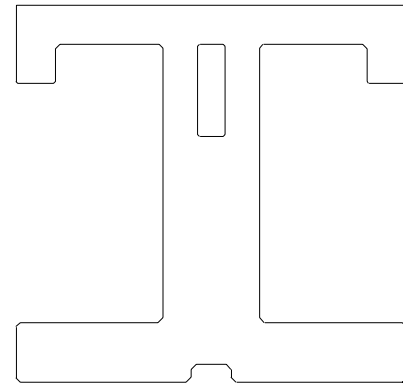



FLORIDA SILVER BULLET

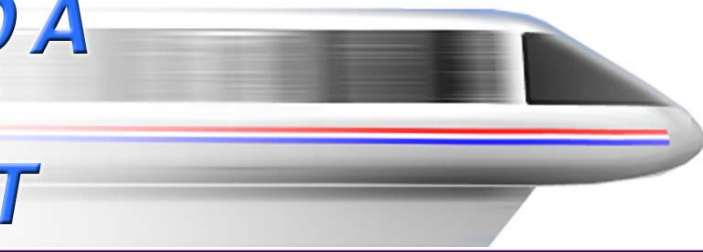

Using the void inside the top of the beam, power can be conveyed to the pantograph bars.

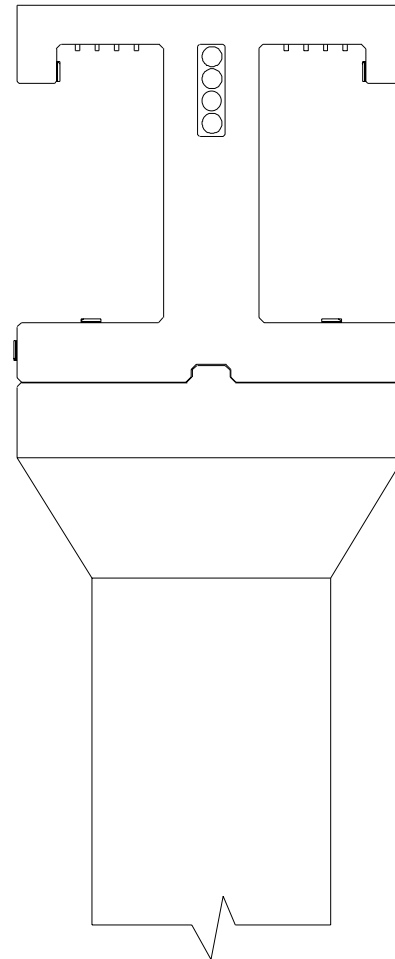



FLORIDA SILVER BULLET



The end of each span is supported by columns which “lock” the beam horizontally.

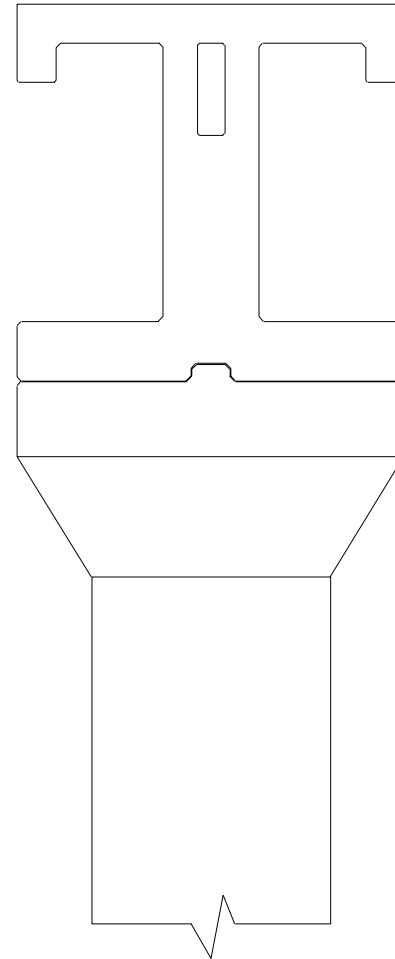



FLORIDA SILVER BULLET

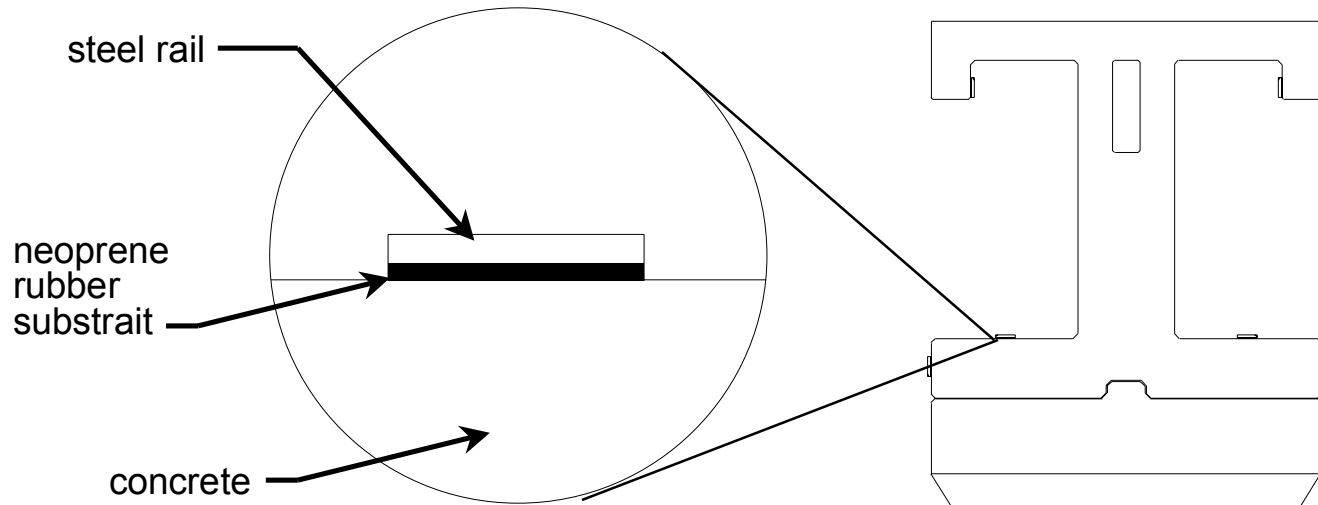
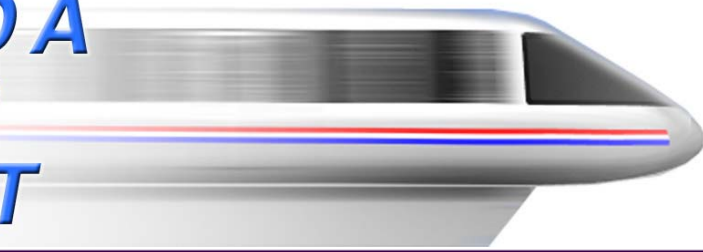

QuietRail technology allows advantages of steel, but with far less noise.



FLORIDA SILVER BULLET

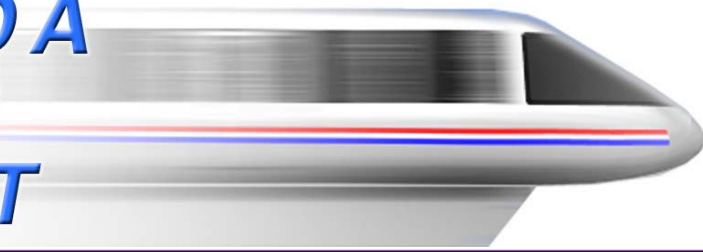

Two simultaneous directions of standard transport and emergency access over traffic congestion or rough terrain.



FLORIDA SILVER BULLET

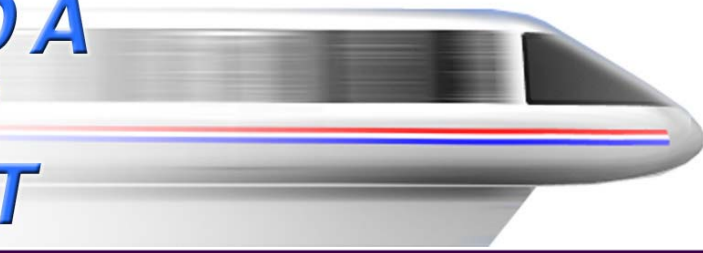

Flangeless steel wheels roll along the rails in 3 planes, locking each vehicle to its side of the guideway beam.

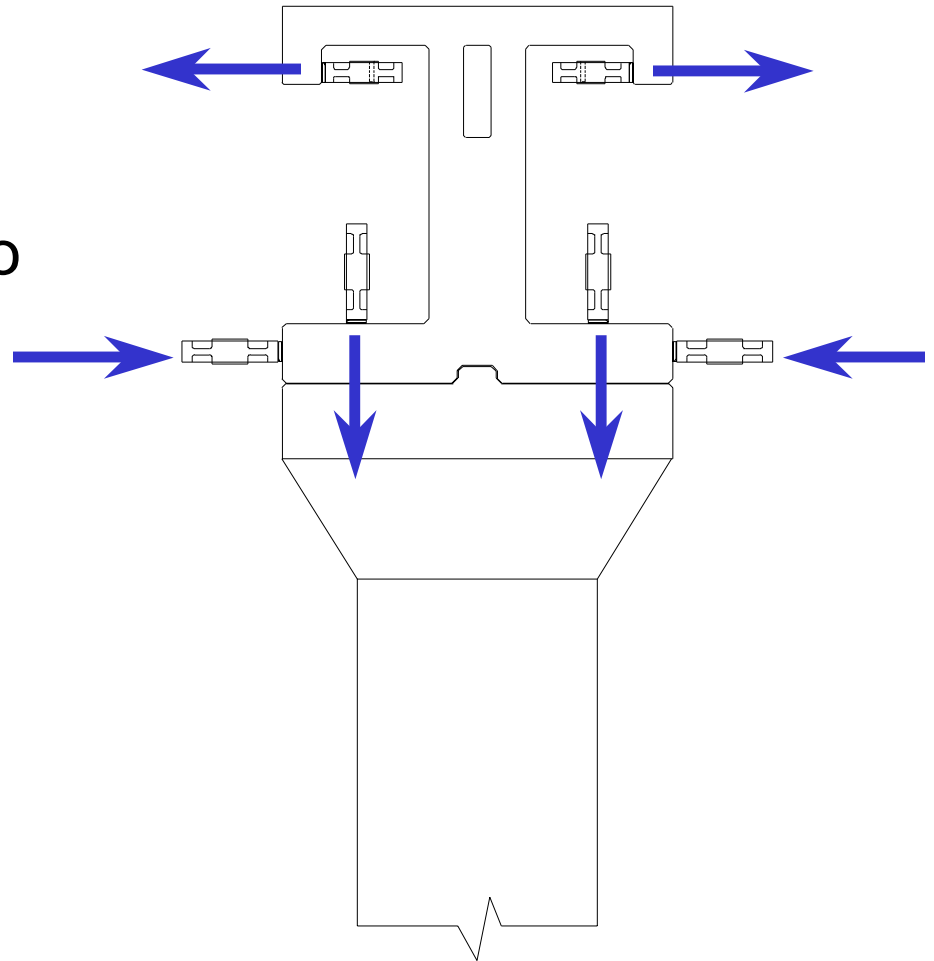



FLORIDA SILVER BULLET

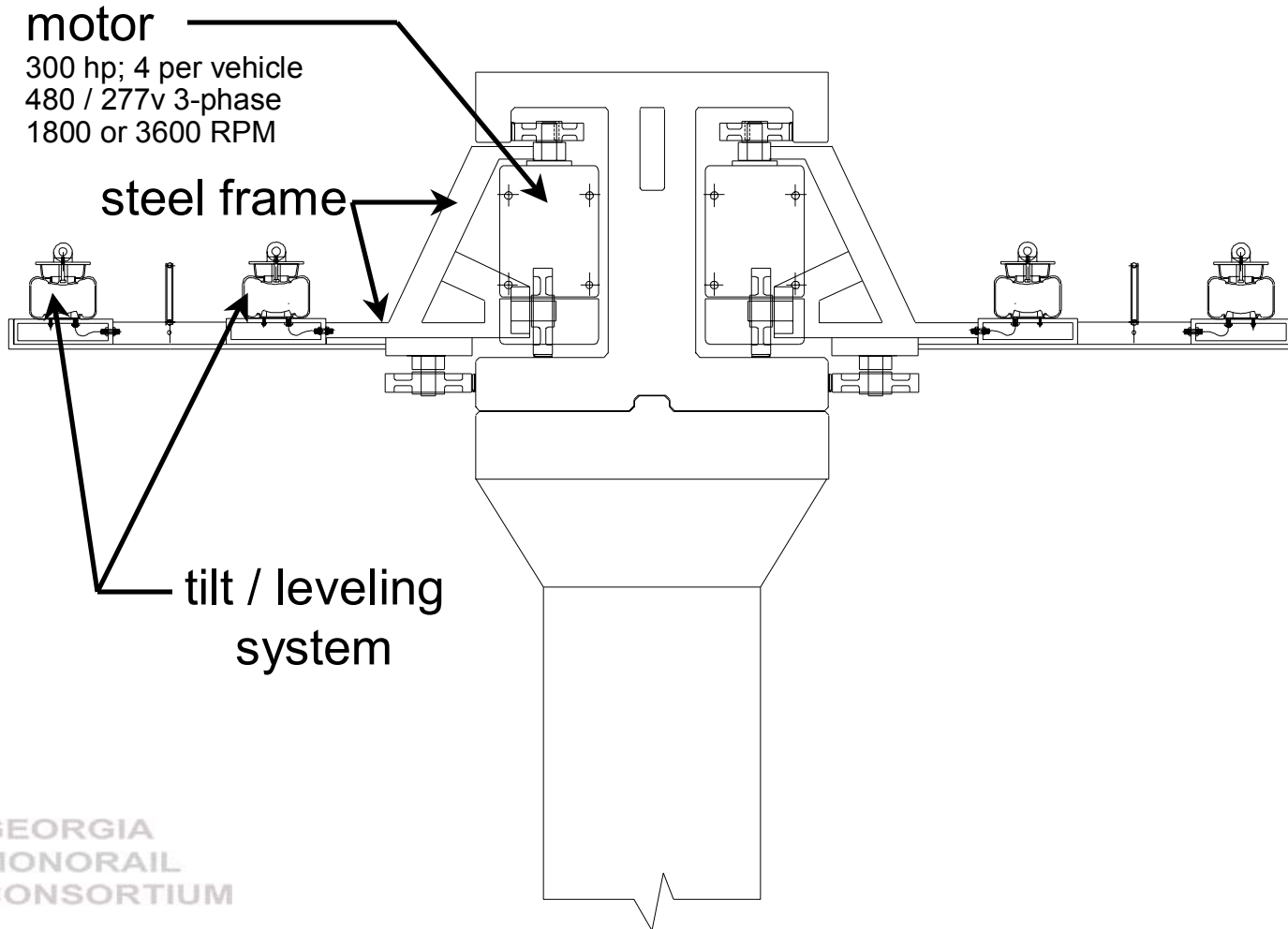
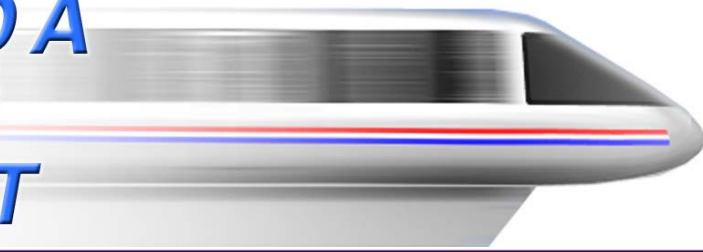



FLORIDA SILVER BULLET



System redundancy is key to reliable vehicle performance.

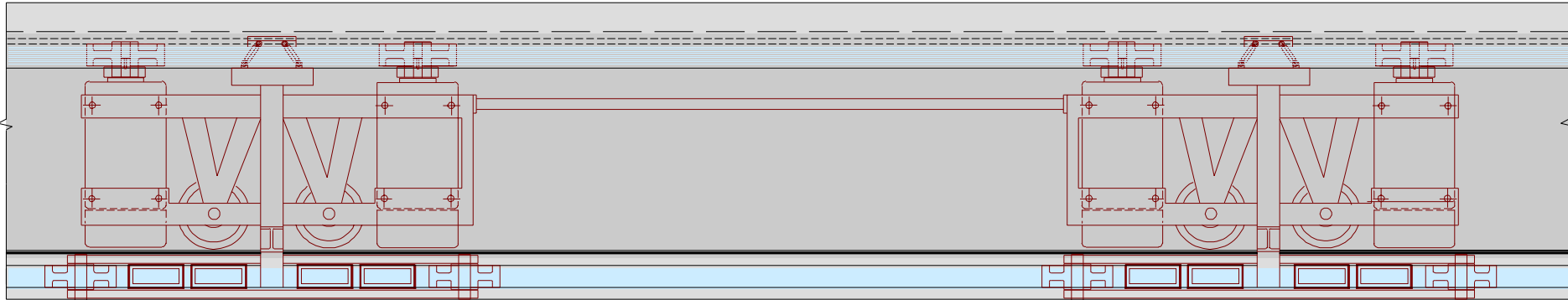

2 drive bogies per
vehicle provide:

- 4 motors
- 4 regenerative brakes
- 8 backup brakes
- 2 power taps (pantographs)





FLORIDA SILVER BULLET

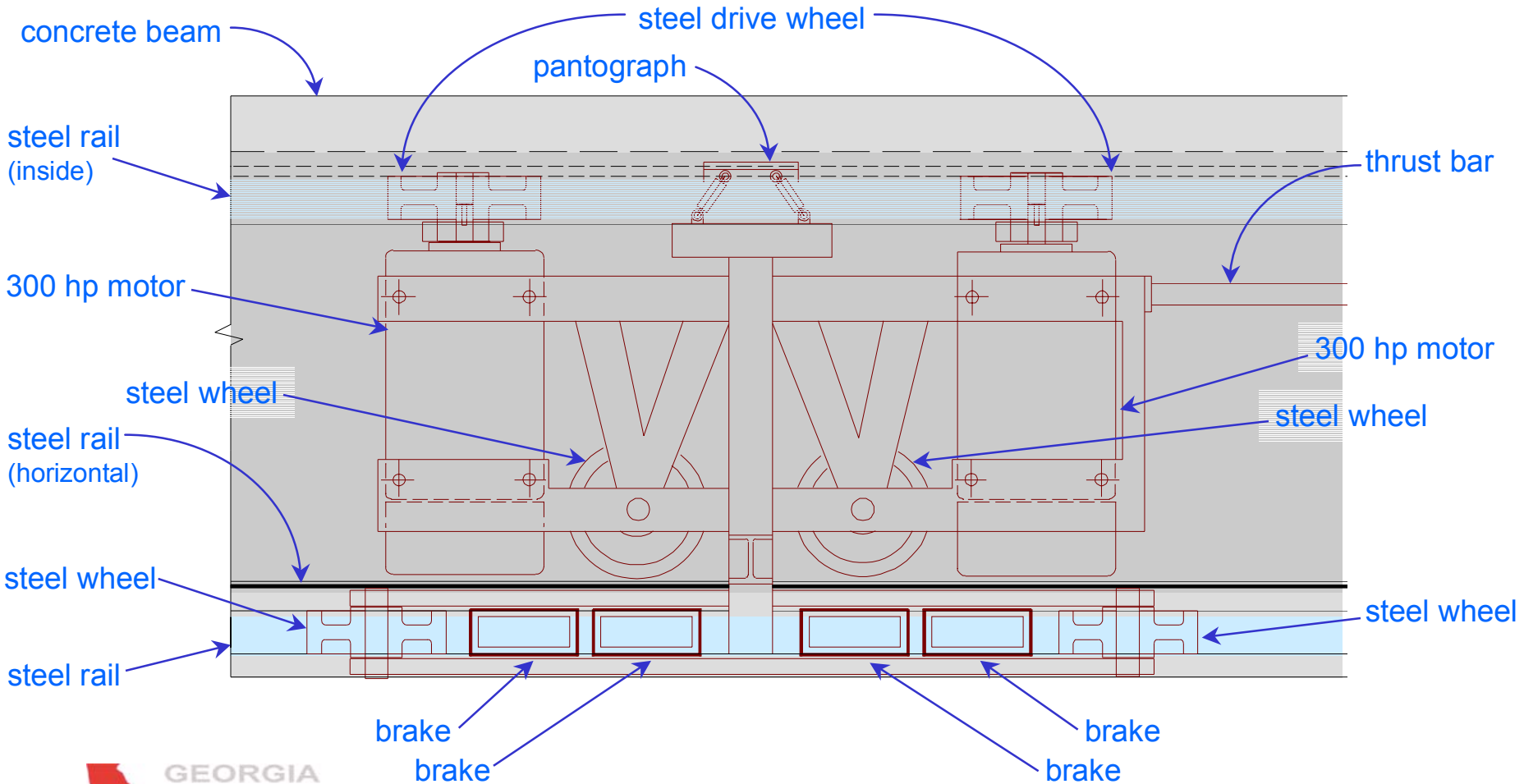
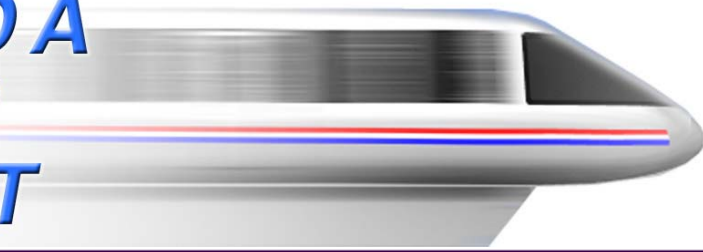

one of two drive bogies per vehicle



FLORIDA SILVER BULLET

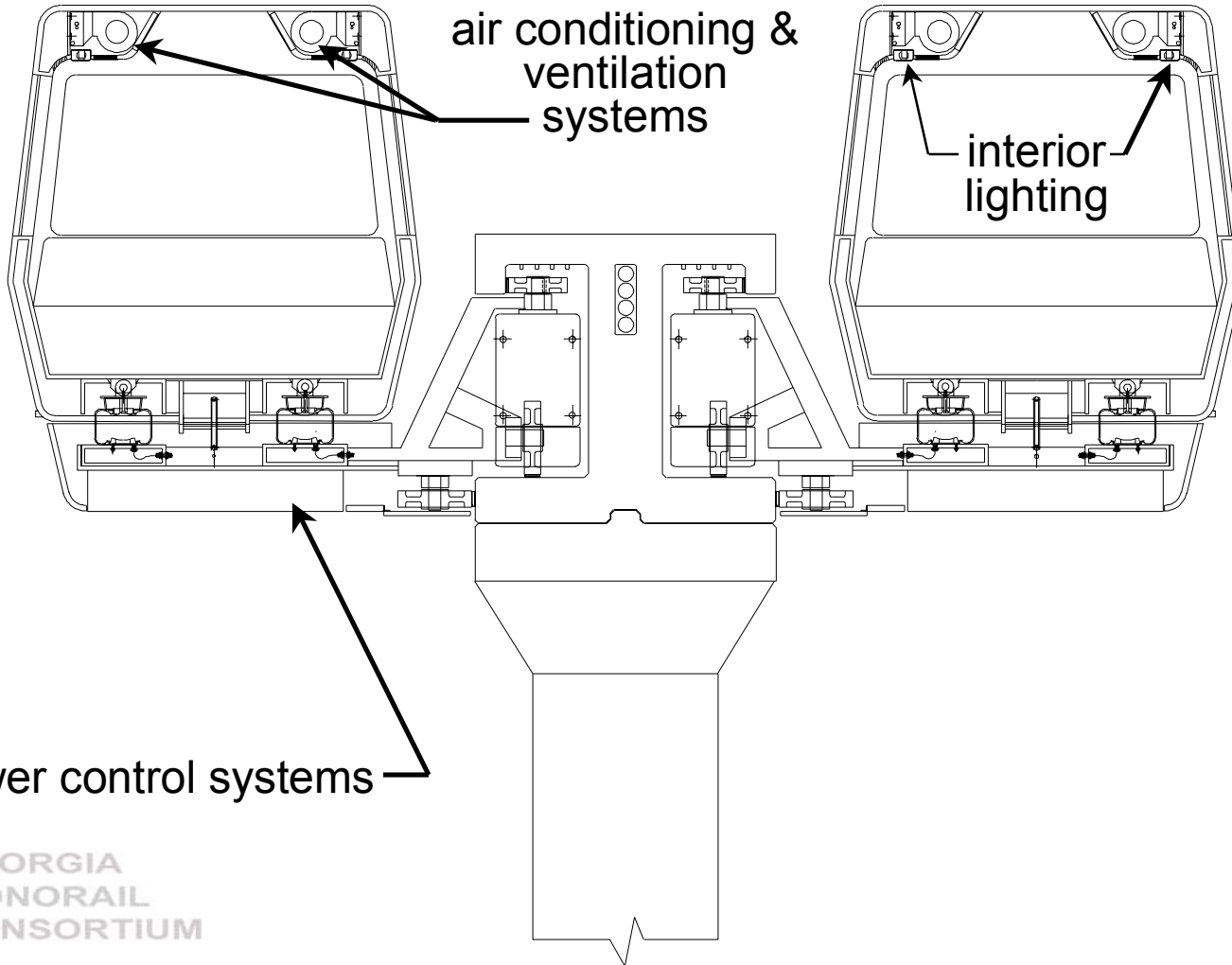
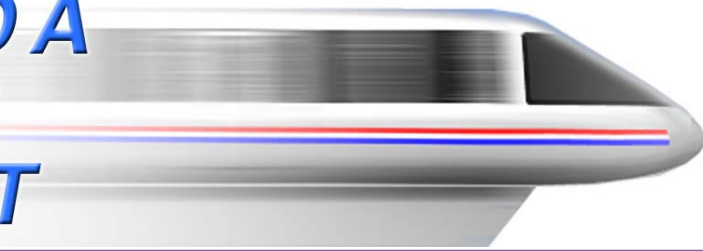

GEORGIA
MONORAIL
CONSORTIUM



FLORIDA SILVER BULLET

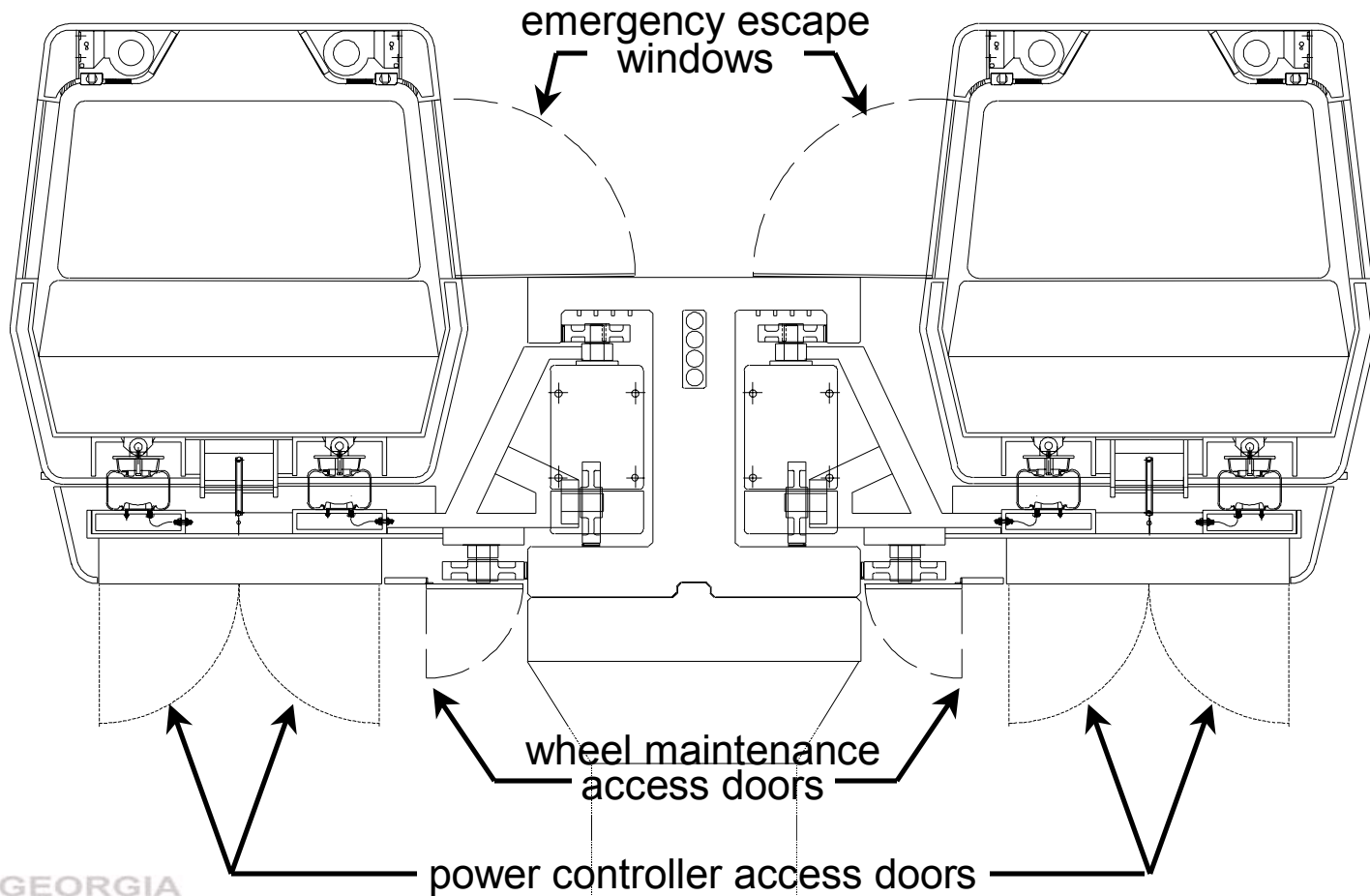
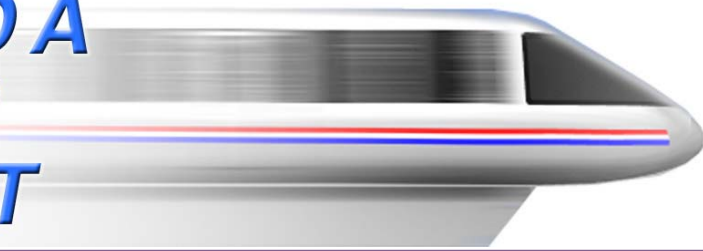



FLORIDA SILVER BULLET

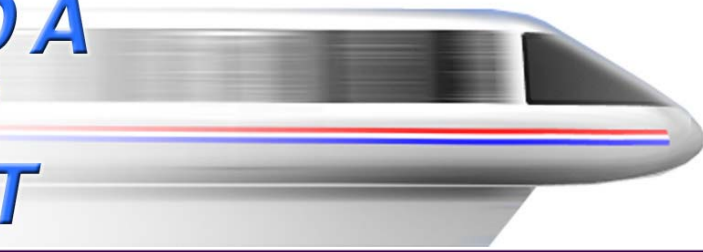

GEORGIA
MONORAIL
CONSORTIUM



FLORIDA SILVER BULLET

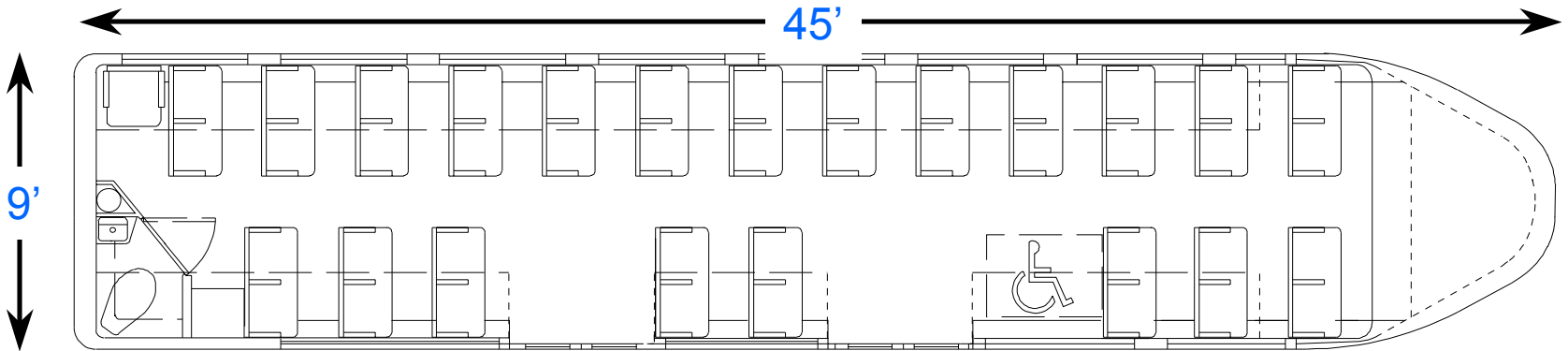
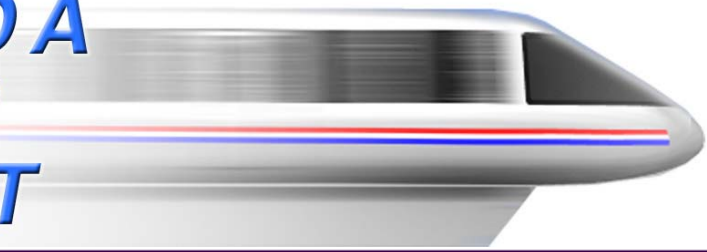

Accommodations: 42 seats
1 wheelchair position
32" seat pitch
18" aisle



FLORIDA SILVER BULLET

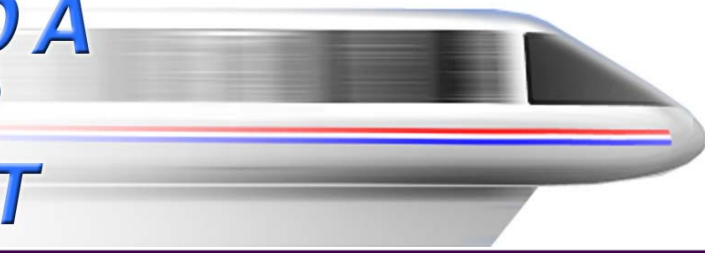

Total Capacity per Vehicle	43 Passengers
Accommodations	42 Standard seats; 1 Wheelchair position; 0 Standing
Maximum Velocity	214 MPH
Minimum Turning Radius	40 Meters (132 feet) vehicle
Headway Minimum	*15 Seconds
Tilt / Leveling Control	Pneumatic
Power	480 Volt / 3 Phase
Power Transfer System	Dual Pantograph
Guideway Type	Dual-sided Monorail
Suspension Type	Pneumatic / Hydraulic
Braking System	Pneumatic / Spring (3 meters/sec/sec)
Door Systems	2 Dual Automatic (bi-parting)
Control Systems	Siemens Digital Controls (Simetric)
Safety Compliance	Full Compliance with ANSI / NFPA-130 Transit Safety Code



FLORIDA SILVER BULLET

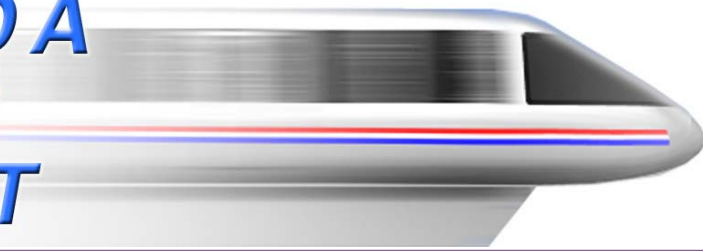

PASSENGERS PER DAY

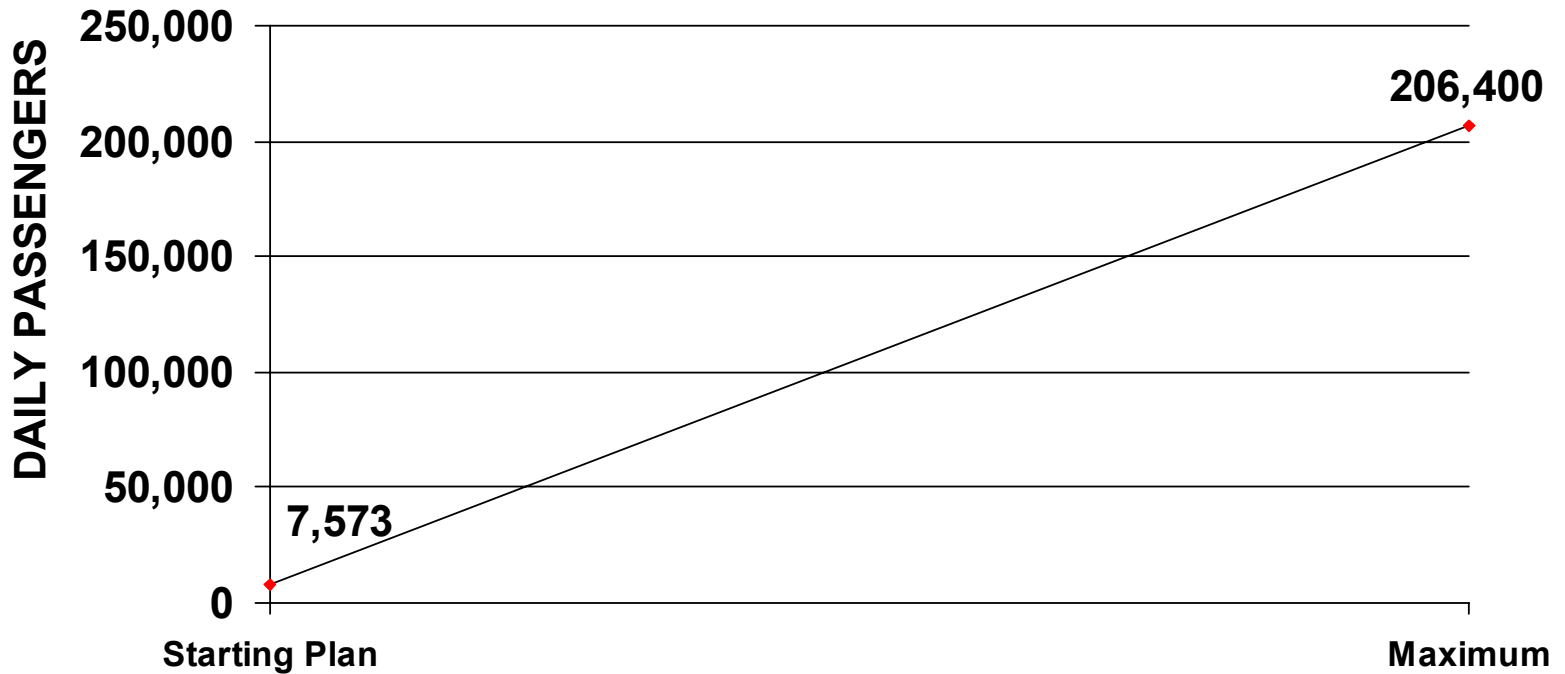



FLORIDA SILVER BULLET

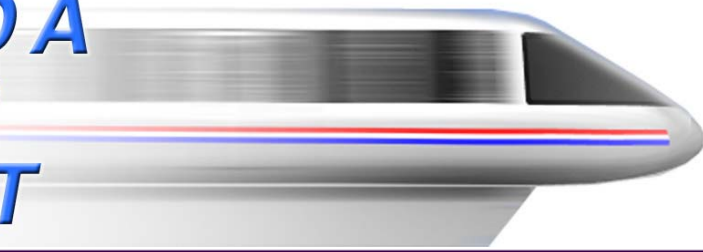

← TRAIN-STYLE STATIONS ARE UP TO 800' →

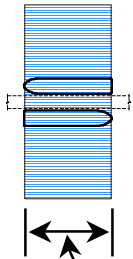

SILVER BULLET
STATIONS ARE ONLY
50' LONG

**High capacity is
achieved through
frequent service rather
than long trains.**



FLORIDA SILVER BULLET



Service Criteria

- 160 Trips / day @ 7 minutes apart
- First-class accommodations
- Airline-style seating
- Overhead storage
- 34 minutes trip time
- 214 mph top speed



FLORIDA SILVER BULLET



Expected Fare Structure

SILVER BULLET

- \$21.75 Orlando to Tampa
- \$2.50 OIA to Civic Center
- \$8.50 Lakeland to Tampa

LOCAL SERVICE

- \$2.00 Orlando Transit
- \$2.00 Tampa / St. Petersburg Transit



FLORIDA SILVER BULLET



Criteria / Conceptual Design Phase Completed

- Designed
- Components pre-existing & selected
- Component costs determined
- Ready for Construction Documents engineering



FLORIDA SILVER BULLET



Well-Known and Respected Team Members:

- WBQ Design & Engineering - construction management
- MACTEC Engineering - civil
- Control Corporation of America - power & controls
- Tindall Corporation - concrete guideway
- AAR Composites - vehicle bodies
- Bradfield, Richards, Rhodes Architects - architecture
- Owen Transit Group, Inc. - technology
- Gen. Jere Akin - logistics consultant
- Lyle Schaefer - testing consultant





FLORIDA SILVER BULLET



Benefits of Using Pre-existing Components

- Quantifiable
- Eliminates unknown factors
- Accurate construction costs
- Accurate construction schedule
- Accurate maintenance schedules
- Accurate operating cost budget
- Creates a predictable & reliable system
- Helps gain Federal Railway Administration approval



FLORIDA SILVER BULLET

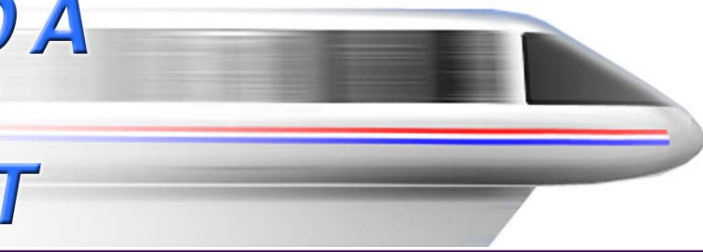

Proposal 1 - Greenway Rt. Option

30-Year Annual Cash Flow

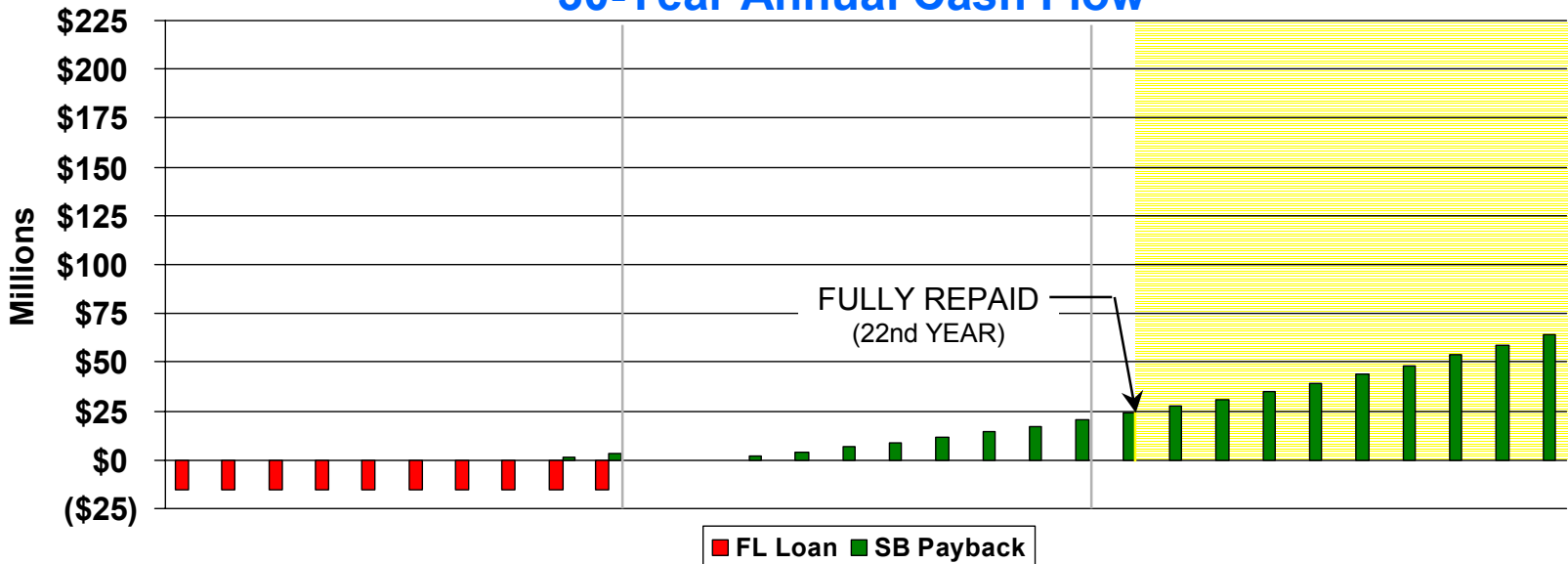

- \$1.40 Billion Total Cost
- State pays \$15 Million / year for 10 years (without captive market considered)
- **Florida receives loans repayment and \$366.1 Million added revenue**



FLORIDA SILVER BULLET

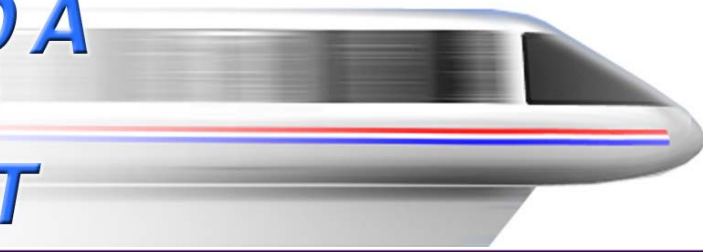

Proposal 1 - Bee Line Rt. Option

30-Year Annual Cash Flow

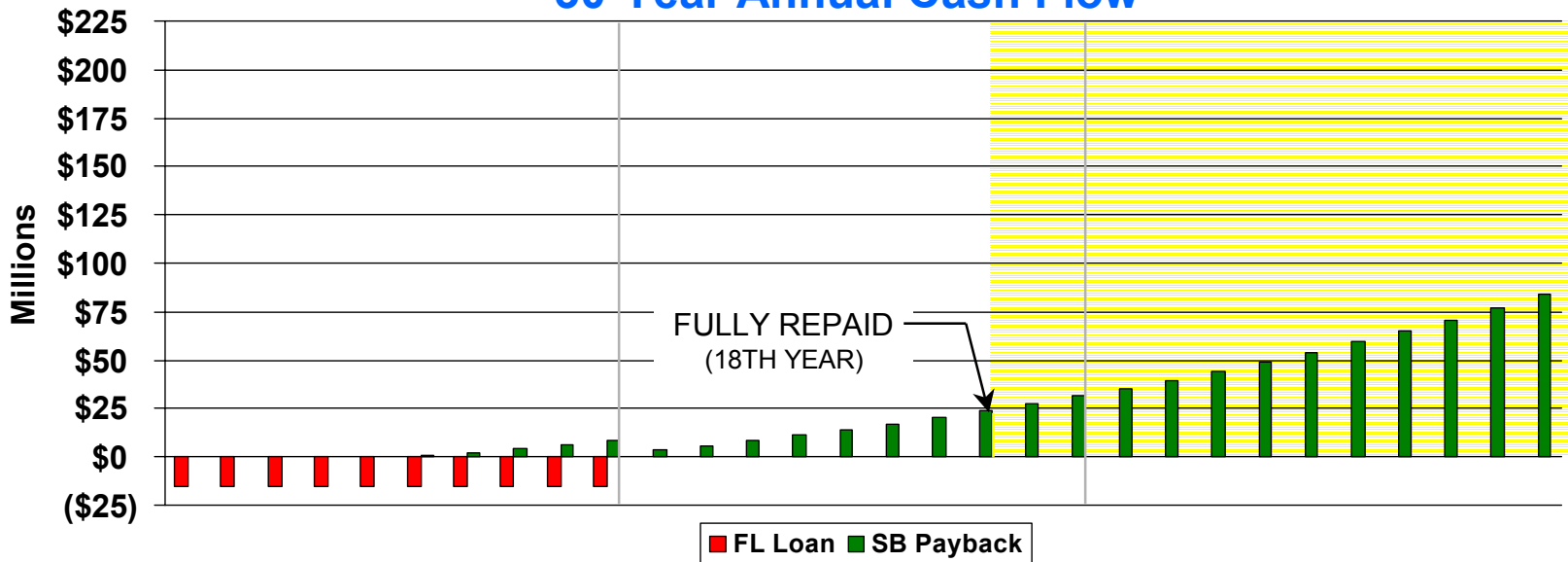

- \$1.452 Billion Total Cost
- State pays \$15 Million / year for 10 years (without captive market considered)
- **Florida receives loans repayment and \$613 Million added revenue**



FLORIDA SILVER BULLET

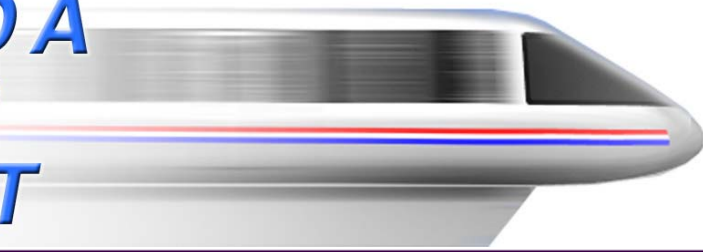

Proposal 2 - Greenway Rt. Option

30-Year Annual Cash Flow

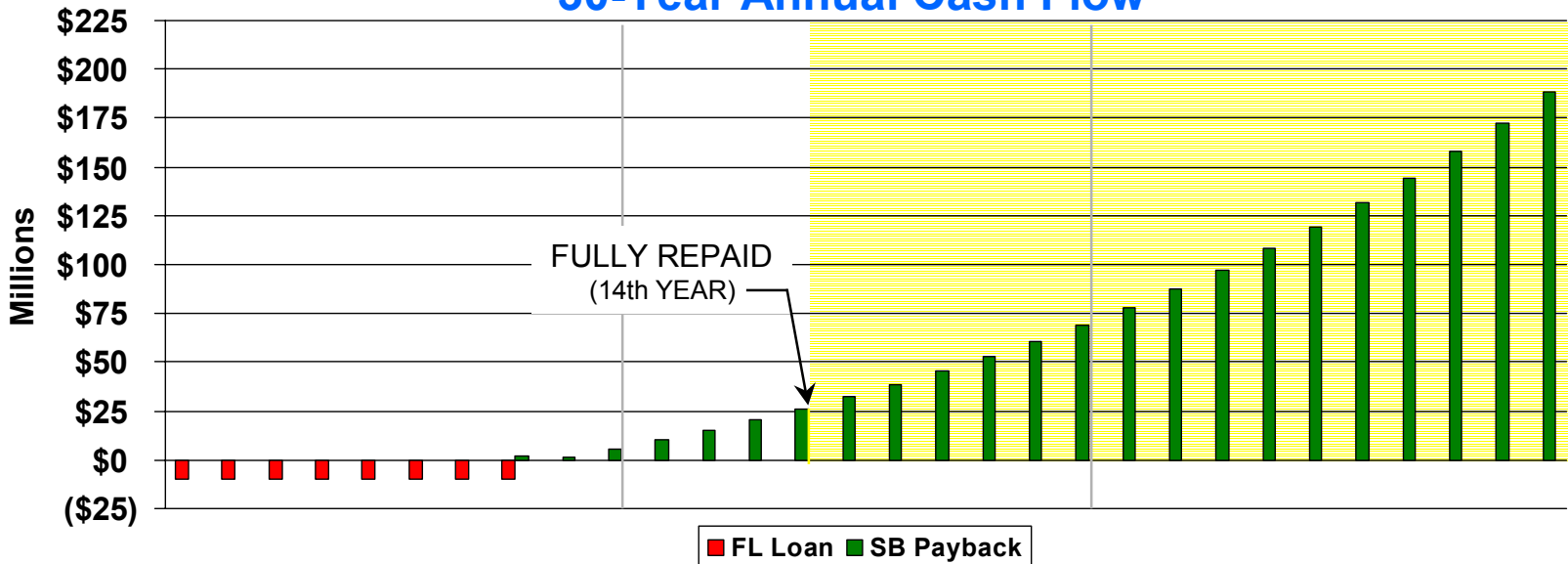

- **Adds local monorail transit service to Tampa / St. Petersburg & Orlando**
- **Total Cost: \$2.48 Billion**
- **State pays \$10 Million / year for 8 years (without captive market considered)**
- **Florida receives loans repayment and \$1.6 Billion added revenue**



FLORIDA SILVER BULLET



Proposal 2 - Bee Line Rt. Option

30-Year Annual Cash Flow

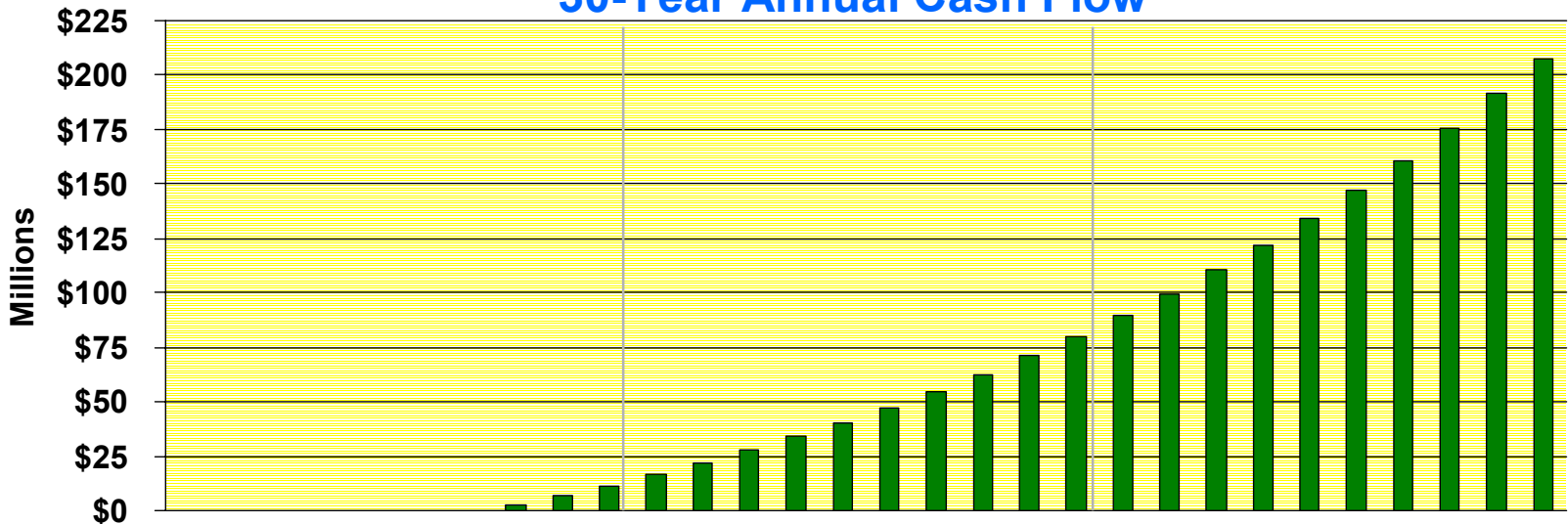

- **Adds local monorail transit service** to Tampa / St. Petersburg & Orlando
- Total Cost: \$2.535 Billion
- **No State or Local funding required**
- Over 30 years, Florida receives **\$1.914 Billion added revenue**



FLORIDA SILVER BULLET



Silver Bullet Meets the Criteria:

- Lowest cost
- Service frequency
- Low fares
- Minimum state funds
- Speed
- Construction time
- FRA acceptance expected



FLORIDA SILVER BULLET

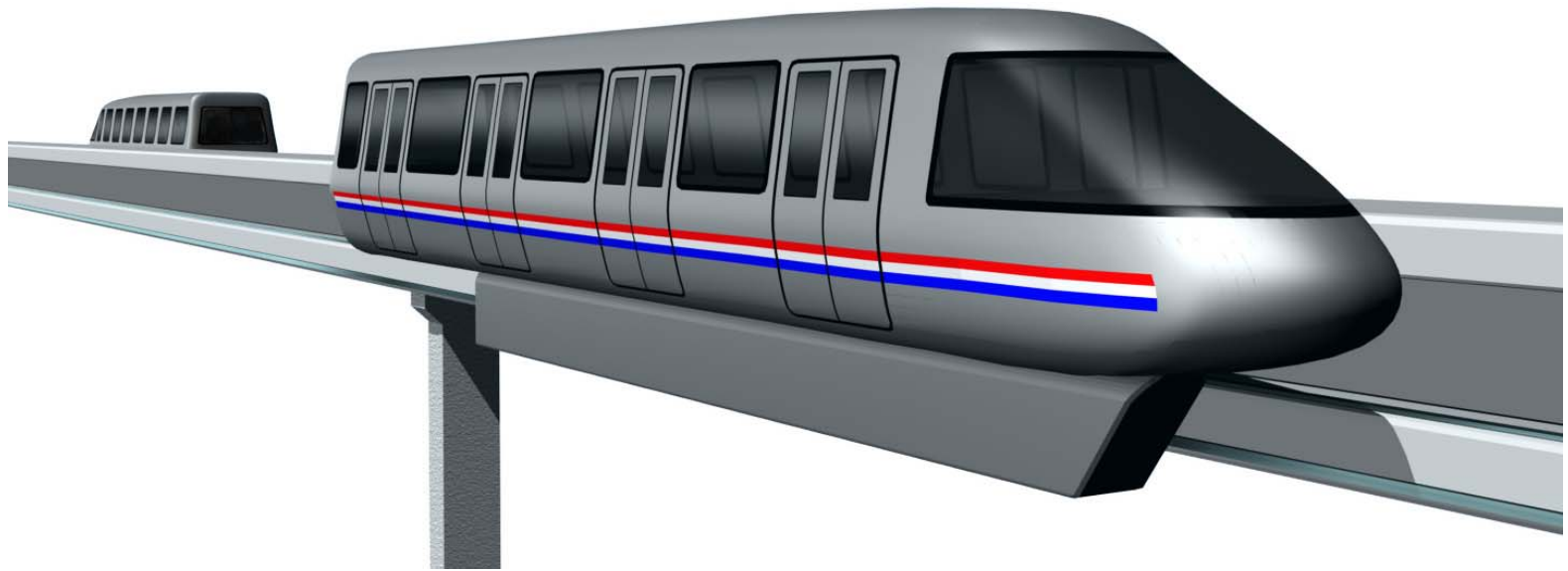
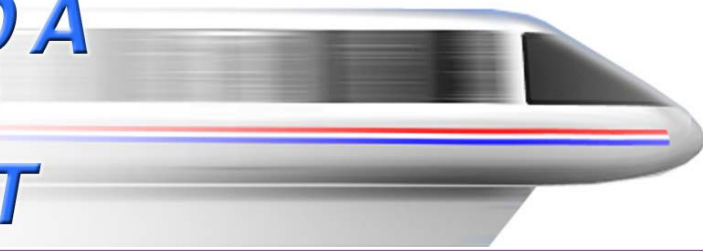

2nd Generation Monorail



GEORGIA
MONORAIL
CONSORTIUM